

1502 SERIES ALL STAINLESS STEEL TEST PRESSURE GAUGE MODEL:1502



Applications:

1502 series pressure gauge is for controlling corrosive pressure systems and whenever high precision pressure measurement is required.

Specifications:

Nominal sizes:

6"

Accuracy:

Cl 0.4, Cl 0.25

Connection:

BSP 1/2" for 6"

Scale Range, according to EN 837-1/5

Pressure ranges: 0 to 1/1.6/2.5/4/6/10/16/25/40/60/100/160/250/400/600/1000 bar

Vacuum range: -1 to 0 bar

Operating Temperature:

Ambient: -40°C to 60°C, medium: 100°C maximum

Material Specification:

Case : AISI 304 steel case and friction ring

Window: instrument glass

Wetted parts: AISI 316 stainless steel bourdon tube and connection

Movement: AISI 304 stainless steel

Options:

NPT, BSPT or other process connection

Restrictor

Mirror scale

Adjustable knob on window

DIMENSION:

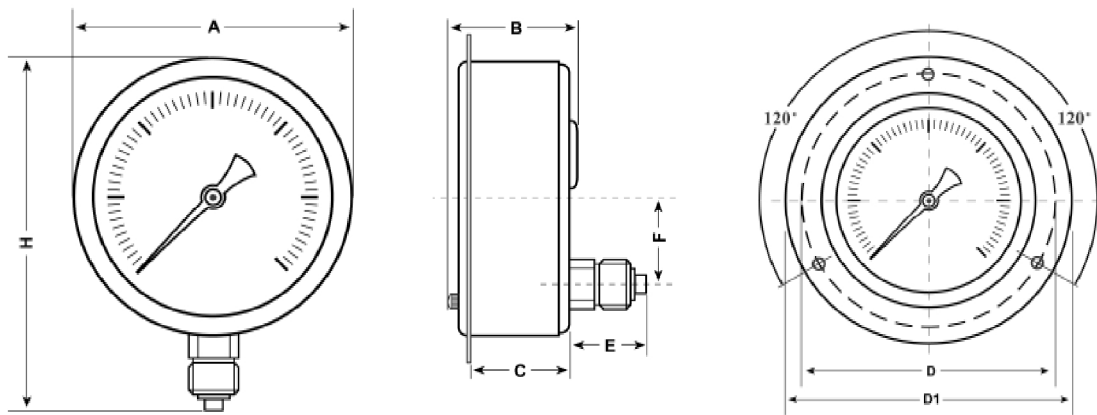

DIAL SIZE	A	B	C	H	D1	D2	E	F
6"	Ø149	58	39	120	Ø166	Ø180	45	47.5

dimensions are approximate and can be changed without prior notice