

Model 1650 , With Magnetic Piston

Applications

- Filter plants
- Pump monitoring
- Cooling circuits
- Pipeline systems

Description

Model 1650 is particularly intended for the monitoring of differential pressures even in the case of high working pressures in gas and air preparation and supply systems.

This piston-type differential pressure gauge offers special advantages due to its compact modular design. For instance an on-the-spot replacement of measuring system and case of indication is possible in retrospect and the Reed contacts can also be retrofitted and adjusted locally.

Design and operating principle

Pressure p_1 and p_2 are given in the \oplus and \ominus measuring medium chambers separated by magnetic piston under pressure or magnetic piston.

The difference in pressure causes axial movement (measuring travel) of the piston supported by a measuring range spring.

A magnetic ring mounted on the instrument pointer follows the magnet's movement in the piston so that each piston position is appropriated to a defined pointer position.

This design ensures complete mechanical separation of the measuring system and the case and eliminates external leakage.

The stream of volume from the \oplus measuring chamber to the \ominus measuring chamber is minimised by the constructive design and will not interfere with the process.

Installation

Pressure entries identified \oplus and \ominus ,
 \oplus high pressure, \ominus low pressure

Mounting by means of

- rigid tailpipes,
- panel mounting (optional extra) or
- device for surface mounting (optional extra)



Illustration of operating principle

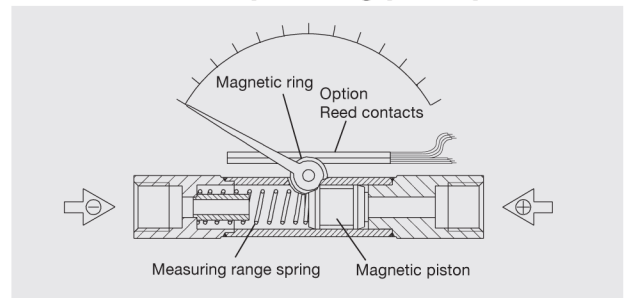

Dimensions in mm

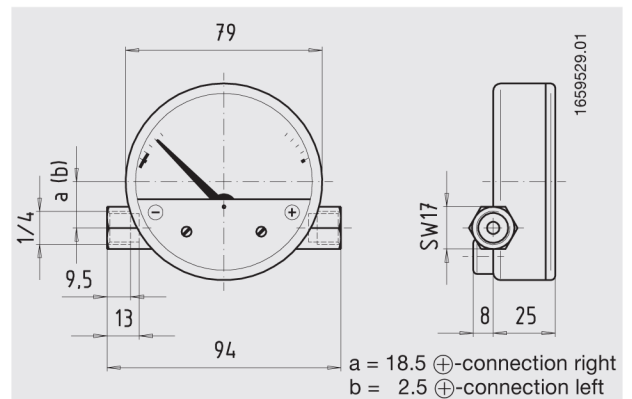

a = 18.5 \oplus -connection right
 b = 2.5 \oplus -connection left

Specifications	Model 1650
Nominal size	80 mm
Accuracy	± 3 % full scale ascending
Scale ranges	0 ... 400 mbar to 0 ... 10 bar
Max. working pressure (static pressure)	Optionally 100, 250 or 400 bar
Operating temperature	
Ambient	0 ... +60 °C
Medium	+100 °C maximum
Ingress protection	IP 54
Pressure chamber with connections (exposed to pressure medium)	Stainless steel 1.4571, 2 x 1/4 female, entry on the right and left, in-line (EN 837-1 / 7.3)
Pressure element (exposed to pressure medium)	Compression spring, stainless steel 304
Magnetic piston (exposed to pressure medium)	Piston: stainless steel 316, magnet: hard ferrite
Dial	White aluminium with dual scale: outer scale black (bar), inner red (psi)
Pointer	Black aluminium
Case of indication	Black aluminium, die-casting
Window	Acryl plastic, snap-fit window