

# Capillary Thermometer

**Application:** For heating and refrigeration

**System:** Liquid expansion

**Model:** CT2470



## Specification:

**Case:** Nickel plated steel case and bayonet ring, case dia 63, 80, 100mm

**Mounting:** Surface mount or Panel mount

**Window:** glass

**Capillaries:** PVC-coated copper; standard lengths 1 - 1,5 metres, other lengths on request. Stainless steel capillary without coating for high temperature on request

**Bulb:** copper

**Sensing element:** Beryllium spiral tube, adjustable at back, with bimetallic compensation

**Dial:** printed aluminum cupped dial. Custom designed dials on request

**Pointer:** aluminum

**Scales:** 0/120°C for heating, -40/+40°C for refrigeration; other scales up to 500 deg C on request.

**Accuracy:** ± 3% of full scale value

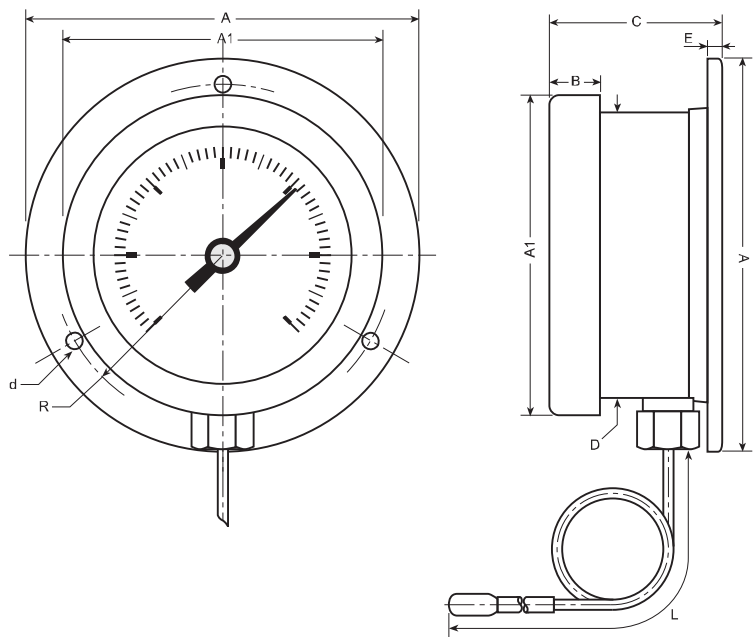

unit:mm

Dial	A	A1	B	C	D	E	R	d	L
63	85.5	69.5	11	37	62	3	37.15	3.6	1-1.5 metres
80	111	84.5	12.5	38.5	75.5	4	46.2	4.6	1-1.5 metres
100	132	109.5	14.5	39	98.5	4	58.7	5.2	1-1.5 metres