

DCS102 SERIES DIAPHRAGM CHEMICAL SEALS, WELDED BODY MODEL:DCS102



Applications:

DCS102 is designed to isolate the sensing element of pressure gauges from process fluids that may be corrosive, viscous, sedimentous and/or with high temperature.

DCS102 is suitable for pressure from -1 to 100bar with thread design.

Specifications:

Instrument connection:

Capillary, 1/4", 1/2" BSP/NPT female

Process connection:

1/4", 1/2" BSP/NPT male or female

Process temperature: -45+150°C

Filling liquid: Silicone oil, glycerin, fluorocarbon oil, vegetable oil

Pressure range: -1-0-100bar

Material:

Gasket: Teflon

Diaphragm: SS 316L, SS316L PTFE coating, SS316L Teflon lined, HC, TI etc

Nuts and bolts: SS 316, SS304

Upper housing: SS 316, SS304

Lower housing: SS 316, SS304

Process and instrument connection: SS 316, SS316L

DIMENSION:

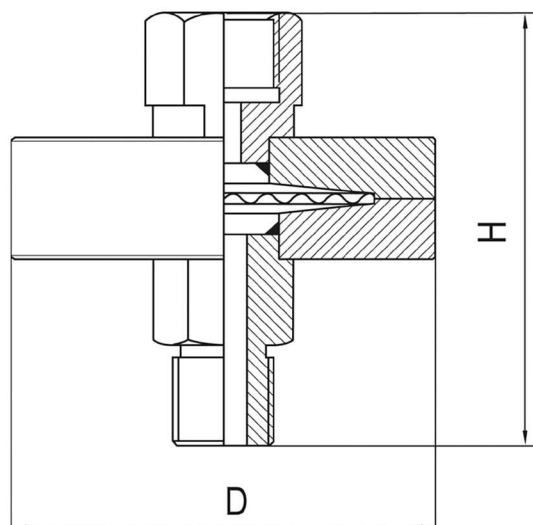

Table Options for Filling Working Fluid

Working Fluid	Diaphragm Seal Temp. range (°C)	Service	Instrument Normal Oper. Temp (°C)
Silicon (Low Viscidity)	- 40°..130°	General	- 30°..50°
Silicon (High Viscidity)	- 30°..240°	High Temp.	- 20°..60°
Fluorocarbon Oil	- 30°..160°	Salt & Acid	- 20°..50°
Glycerine	- 5° ..100°	Food	- 5° ..40°
Propylene Glycol	- 30°..100°	Food	- 20°..40°

Standard Working Fluid is Silicon (Low Viscidity)

Technical Dimension and Characteristic

Model	Dimension and Characteristic			
	D	H	Pressure	Weight
DCS 102	88	86	-1 ≤ P ≤ 100 Bar	1,20 kgs