

## DCS202 SERIES DIAPHRAGM SEAL FLAT FLANGE END



### Applications

DCS202 is designed to isolate the sensing element of pressure gauges from process fluids that may be corrosive, viscous, sedimentous and/or with high temperature.

DCS202 is suitable for pressure from -1 to 40 bar with flat flanged end design.

### Specification

Instrument connection: 1/2" BSP female

Process connection: Flange 3/4" ANSI 150#

Process temperature: -45+150°C

Filling liquid: silicone oil

Pressure range: -1-0-40bar

### Dimensions

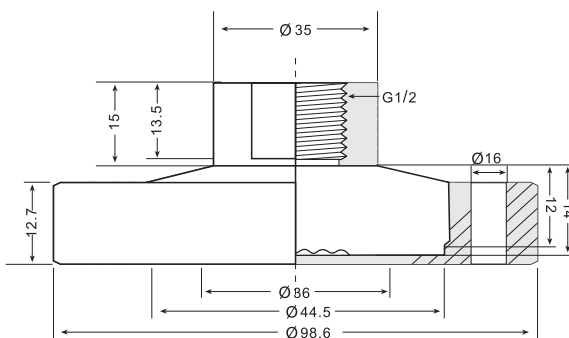

### Material

Housing: SS 316

Diaphragm: SS 316L